



高精度行星减速機

HIGH PRECISION PLANETARY GEARBOX



经营理念

细节决定成败 服务改变未来。

Business Philosophy
Details make or break a service that changes the future.

诚信为本

一个长久的企业立足于信誉、以诚待人——这是做人的品质、立业之根本，我们对客户、对同事都坚持重信誉、守信用的原则，金钱诚可贵，信誉价更高。

Integrity is everything
A long-term enterprise based on reputation, treat people with sincerity -- this is the quality of life, the foundation of career. We insist on the principle of credit and trustworthiness to our clients and colleagues, the money is precious, the credit value is higher.

稳健发展

公司对可持续稳定发展是我们不懈的追求，员工不断发展与进步是公司的责任。崇铭不仅是一个经营产品的公司，更是一家开发人力资源的公司。

Steady Development
Sustainable and stable development of the company is our unremitting pursuit of staff development and progress is the responsibility of the company. Chong Ming is not only a company operating products, but also a company developing human resources.

质量方针

公司逐步健全推行质量保证体系，在管理上坚持：“优秀人才、优秀品质、优秀服务”。
推行：零缺陷服务，为用户提供更高水平的服务。

Quality Policy
The company gradually improve the implementation of quality assurance system, in the management of adhere to: "excellent talent, excellent quality, excellent service. ". Implementation: Zero Defect Service, to provide users with a higher level of service.

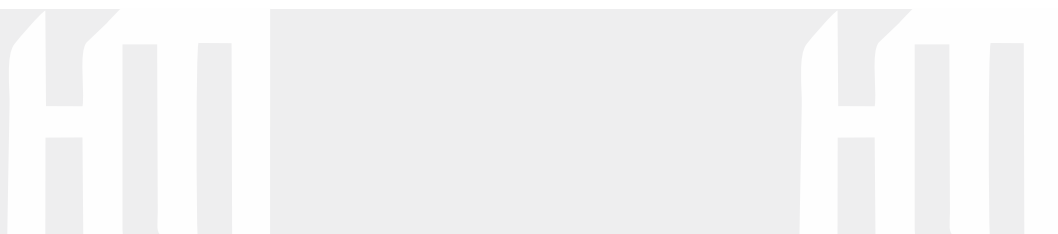



上海动展传动机电有限公司
SHANGHAI DONG ZHAN DRIVE INDUSTRY CO.,LTD.



DM

DM

>> 产品系列目录



YADR

P 056

特征	Features	P 056
机种、型号代码	Model number	P 056
性能一览表	Performance table	P 057
尺寸一览表	Dimensions	P 058



YPGX

P 065

特征	Features	P 065
机种、型号代码	Model number	P 065
性能一览表	Performance table	P 066
尺寸一览表	Dimensions	P 067



YPGE

P 075

特征	Features	P 075
机种、型号代码	Model number	P 075
性能一览表	Performance table	P 076
尺寸一览表	Dimensions	P 078



YPGER

P 085

特征	Features	P 085
机种、型号代码	Model number	P 085
性能一览表	Performance table	P 086
尺寸一览表	Dimensions	P 087

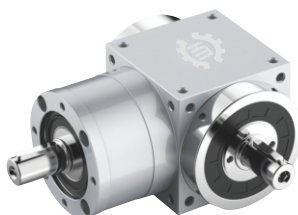

YAT

P 091

特征	Features	P 091
机种、型号代码	Model number	P 092
性能一览表	Performance table	P 093
尺寸一览表	Dimensions	P 095



YHT

P 114

特征	Features	P 114
机种、型号代码	Model number	P 114
性能一览表	Performance table	P 115
尺寸一览表	Dimensions	P 116

马达安装说明 Motor installation instructions

P 118

安全注意事项 Safety precautions

P 120

产品特性

Products Features



行星齿轮的传动介面采用**不含保持架之满滚针设计**，增加接触面积以提高结构刚性及输出扭矩。



减速机构采用**螺旋齿轮设计**，其齿形啮合率为一般正齿轮的两倍以上，具有运转平顺、低噪音、高输出扭矩和低背隙的特性。



输入轴与马达的连接采用**筒夹式的锁紧机构**并经**动平衡分析**，以确保在高输入转速下接口的同心度和零背隙的动力传递。

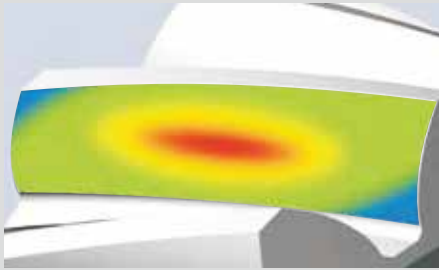

利用ANSYS技术对齿轮强度进行**有限元分析**，同时对齿面作**齿形及导程修整**，以减低齿轮啮合的冲击和噪音，增加齿轮系的使用寿命。

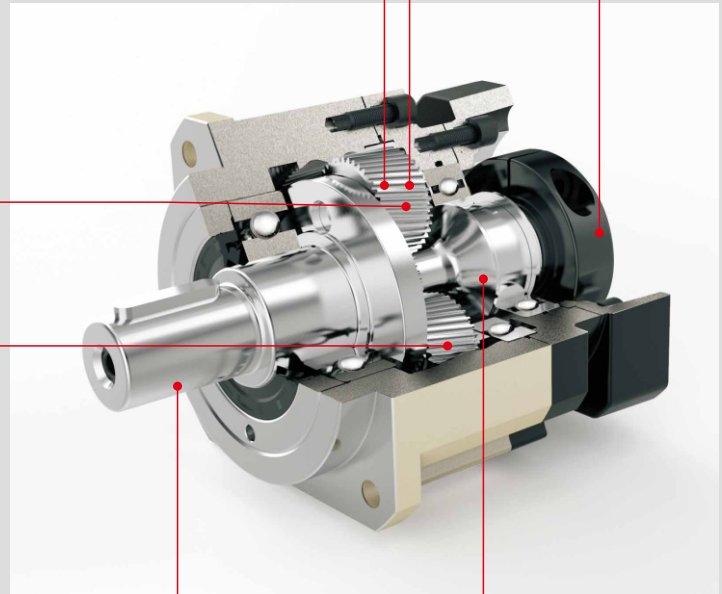

齿轮材料采用**优质合金钢**，经**碳-氮共渗处理**，从而获得最佳的耐磨性和耐冲击韧性。

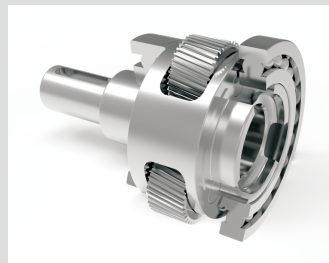

行星架与输出轴采用**一体式双支撑的结构设计**，确保最大的扭转刚性。



太阳齿轮与输入轴采用**一体式的结构设计**，确保最大的扭转刚性及高输入转速下的零背隙动力传递。

产品特点/products features

精密行星齿轮减速机是我公司研发的新一代实用性产品，具有以下一些主要特点：

- 1.低噪音: 低于65db。
- 2.低背隙: 单级可达1弧分内，双级可达3弧分内。
- 3.高效率: 单段式在95%以上，双段式在92%以上。
- 4.高输入转速: 可达8000RPM。
- 5.高扭矩: 比一般标准行星减速机扭矩高。
- 6.高稳定性: 采用高强度合金钢材，整颗齿轮经硬化处理，非只有表面硬化，确保使用寿命及长期使用仍保持最初的精密程度。
- 7.高减速比: 采用模组化设计，行星齿箱可相互连结，速比可达1/1000以上。

The precision planetary gear reducer is a new-generation practical product developed by our company. It has the following main features:

- 1.Low Noise: Under 65db.
- 2.Low Backlash: Backlash is under 1 arcmin.Backlash for 2-stage speed reduction is within 3 arcmin.
- 3.High Efficiency: Efficiency for 1-stage model exceeds 95% ,For 2-stage model exceeds 92%.
- 4.High Input Speed: Input speed allows for up to 8000 RPM.
- 5.High Torque: Higher torque output than that of conventional planetary gear reducers.
- 6.High Stability: Employs high tensile strength alloy steel.Gear hardening is made for the entire gear instead of only surface hardening,which extends gear service life and maintain high accuracy as new after a long period of operation.
- 7.High Speed Reduction Ratio: The gear reducer is a modular deign.The planetary gear box can be connected.Speed reduction ratio is over 1/1000.

产品用途/Precision usage

精密行星齿轮减速机被广泛应用于以下领域：

- 1.航空航天、军事产业。
- 2.医疗卫生、电子信息技术产业。
- 3.工业机器人、生产自动化、数控机床制造产业。
- 4.汽车制造、纺织、印刷、食品、冶金、环保工程、仓储物流等产业。

Precision Planetary Gear Reducer is widely used in the following domain:

1. Aerospace, military industry.
2. Medical health, electronic information industry.
3. Industrial robots, Production automation, CNC machine tool manufacturing industry.
4. Motor, textile, printing, food, metallurgical, environmental protection engineering, warehouse logistics industr.

減速機的選用

Reducer selection

如何選用減速機

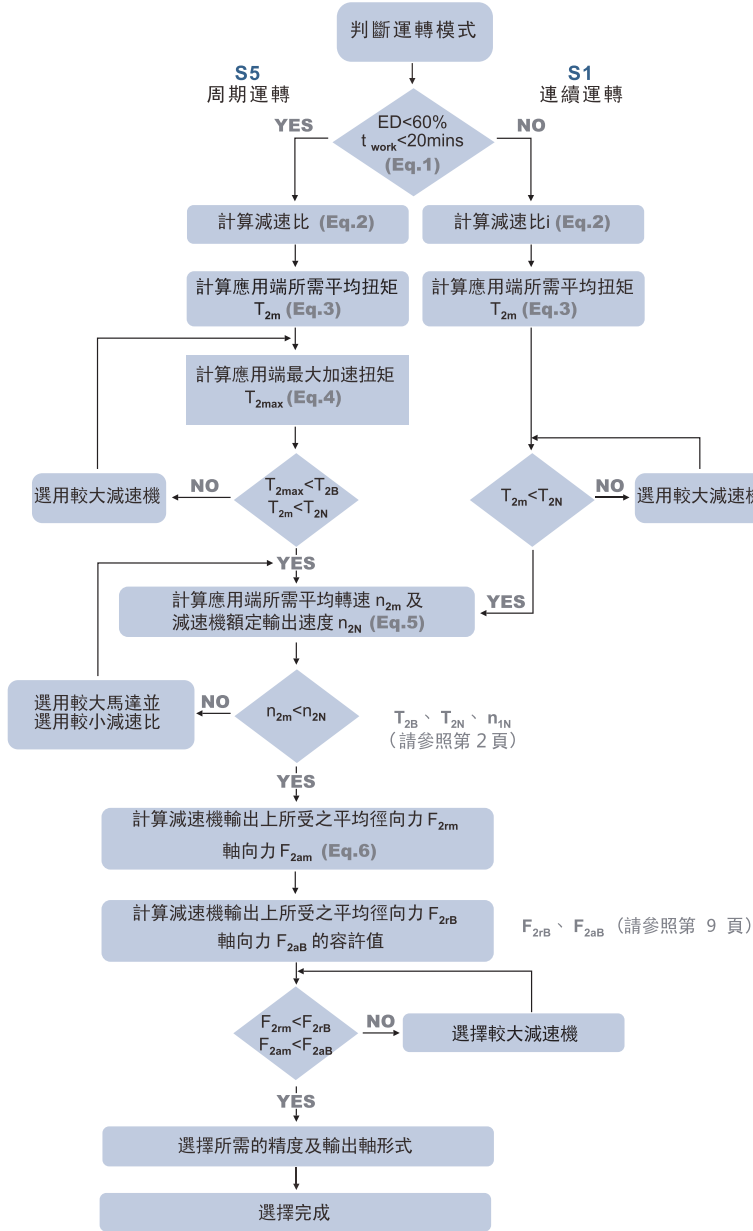

S5 周期運轉之建議事項

壹般的應用慣量須符合以下公式:

$$\frac{J_L}{i^2} \leq 4 \times J_m$$

最適當的應用慣量須符合查下公式:

$$\frac{J_L}{i^2} \cong J_m$$

J_L 負載慣量

J_m 馬達慣量

應用端運動模式

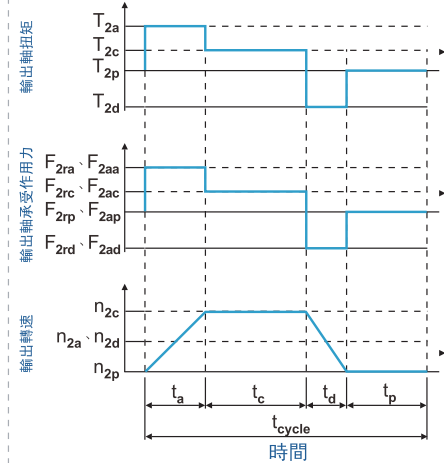

$$1. ED = \frac{t_a + t_c + t_d}{t_{cycle}} \times 100\%, t_{work} = t_a + t_c + t_d$$

下標說明: a. 加速, c. 等速, d. 減速, p. 停止 (Eq.1)

$$2. i \cong \frac{n_m}{n_{work}}$$

n_m 馬達輸出速度

n_{work} 實際應用速度

(Eq.2)

$$3. T_{2m} = \sqrt[3]{\frac{n_{2a} \times t_a \times T_{2a}^3 + n_{2c} \times t_c \times T_{2c}^3 + n_{2d} \times t_d \times T_{2d}^3}{n_{2a} \times t_a + n_{2c} \times t_c + n_{2d} \times t_d}}$$

(Eq.3)

$$4. T_{2max} = T_{mB} \times i \times k_s \times \eta$$

k_s 負載係數

k_s	周期次數/小時
1.0	0 ~ 1,000
1.1	1,000 ~ 1,500
1.3	1,500 ~ 2,000
1.6	2,000 ~ 3,000
1.8	3,000 ~ 5,000

T_{mB} 馬達最大輸出扭矩

η 減速機運轉效率

(Eq.4)

$$5. n_{2a} = n_{2d} = \frac{1}{2} \times n_{2c}$$

$$n_{2m} = \frac{n_{2a} \times t_a + n_{2c} \times t_c + n_{2d} \times t_d}{t_a + t_c + t_d}$$

$$n_{2N} = \frac{n_{1N}}{i} \quad (Eq.5)$$

$$6. F_{2rm} = \sqrt[3]{\frac{n_{2a} \times t_a \times F_{2ra}^3 + n_{2c} \times t_c \times F_{2rc}^3 + n_{2d} \times t_d \times F_{2rd}^3}{n_{2a} \times t_a + n_{2c} \times t_c + n_{2d} \times t_d}}$$

$$F_{2am} = \sqrt[3]{\frac{n_{2a} \times t_a \times F_{2aa}^3 + n_{2c} \times t_c \times F_{2ac}^3 + n_{2d} \times t_d \times F_{2ad}^3}{n_{2a} \times t_a + n_{2c} \times t_c + n_{2d} \times t_d}} \quad (Eq.6)$$

减速机的选用及注意事项

Gear unit selection & announcements

与选型有关的基本概念/Base concepts of precision planetary gear boxes

Ratio/减速比 Input speed/Output speed 输出转速比上输入转速

额定输入转速 n_1 [rpm] 减速机的驱动速度，若减速机与电机直接相连，则转速值与电机转速相同。本书中的额定输入转速是在环境温度为20°C的条件下测得的。环境温度较高时请降低转速 n_1

输出转速 n_2 [rpm] 输出转速按照下列公式通过输入转速 n_1 和传动比*i*计算出来： $n_2 = n_1 / i$

Poles 段/级数 The number of set of planetary gear. Owing to one set planetary gear can't satisfy bigger transmission ratio,two or three sets can meet Users' requirements of bigger transmission ratio. Since increasing the gear quantity,the length of two or three poles motor will increase accordingly,of course,the efficiency will reduce accordingly.
行星齿轮的套数。由于一套行星齿轮无法满足较大的传动比，有时需要两套或三套来满足用户对较大传动比的求，也就是说，减速比越大段/级数越多。由于增加了行星齿轮的数量，所以二级或三级减速机的长度会有所增加，效率会有所下降。

Efficiency 传动效率 If refers to the gearing efficiency of the gearboxes in the case of the largest load.
指在额定负载情况下，减速机的传输效率。减速比越大，级数越多，效率越低。

Average lifetime 平均寿命 Refers to the continuous working time of the gearboxes of the highest input rev.
指减速机在额定负载下，额定输入转速是减速机的连续工作时间。

Precise positioning 定位精度 In high-speed reciprocating mechanical movement achieve precise positioning is the key to minimizing the movement through the angular deviation,positioning accuracy depends on the two values,with a load of the deflection angle,involving a return to space with torsion stiffness,and the other is control of the movement and rotation angle,involving partial synchronization the problem worse.
在高速机械往复运动中做到精确定位的关键在于尽量减小通过运动产生的角偏差。定位精度取决于两个值，一个是与加载有关的偏转角，涉及到回程间隙和扭转刚度；另一个是与运动控制有关的偏转角，涉及到同步偏差问题。

Backlash 回程间隙背隙 减速机输出轴与输入轴的最大偏差角，测量时先将齿轮输入轴固定住，然后在输出轴用力矩仪加载一定力矩（2% T_{2B} ），以克服减速机内的摩擦力。

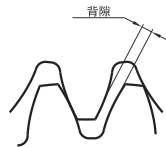

迟滞曲线 迟滞曲线是为了得出减速机的扭转刚度，通过检测得到迟滞曲线。检测时，先将减速机输入端固定住，然后在输出端的两个旋转方向分别持续地加载到 T_{2B} 最大输出力矩，继而逐步卸载，用仪器记录下力矩的仿差角，得到的曲线是一条闭合曲线，从中可以计算出减速机制回程间隙（ j_r ）和扭转刚度（ C_{t21} ）。

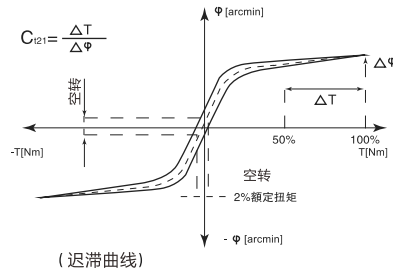

Inertia 转动惯性 Moment of the rotary inertia in this description refers to that at the input terminal.Said an object strive to maintain their rotational state(or a stationary of rotating)characteristics of a value.
本说明书中的该值均指输入端。表示一个物体尽力保持自己转动状态（或静止或转动）特征的一个值。

The proportion of inertia 惯量比 Refer to the ration of load inertia and inertia drive system(motor with gearbox).This ratio determines the controllability of the λ value,the greater is the moment of inertia greater margin,high-dynamic action on the more difficult process of precision control.The values can be control in 5,gearboxes can be used to reduce load $1/i^2$.
是指负载惯量与传动系统惯量（电机加上减速机）之间的比值。这个比值决定了系统的可控性。 λ 值越大，也就是各转动惯量差值越大，高动态的动作过程就越难精确控制，建议尽可能将 λ 值控制在 < 5 。齿轮箱可以将负载惯量降低 $1/i^2$ 。

Noise 噪音 The unit is decibel(dB).The value is measured when the input rev is 3000r/m without load and at the distance of one meter from the gearboxes.
单位是分贝（dB）。此数值是在输入转速为3000转/分时，不带负载，距离减速机一米距离时测量的。

Operating conditions 工作条件

Operating temp/工作温度°C	-10°C~+90°C
Degree of protection/防护等级	IP54/IP65
Lubrication/润滑	Life time lubrication/长效润滑，整个试用期内无需添加润滑剂
Mounting position/安装方式	Any/任意

减速机的选用及注意事项

Gear unit selection & announcements

与选型有关的基本概念/Base concepts of precision planetary gear boxes

额定输出扭矩 T_{2N} [Nm]	T_{2N} [Nm]减速机长时间（连续工作制）可以加载的力矩（无磨损），条件应满足负载均匀，安全系数 $S=1$, FPG160/FAB142以下机型，理论寿命为20000小时；FAB180以上机型理论寿命为10000小时； T_N 值遵守 ISODP6336齿轮标准与ISO281轴承标准。
加速扭矩 [Nm]	指工作周期每小时少于1000次时允许短时间加载到输出端的最大力矩。工作周期每小时大于1000次时，须考虑冲击因素。加速扭矩是周期工作制选型时的一个最大值，实际使用中的加速力矩必须小于 T_{2B} ，否则会缩短减速机的寿命。
紧急制动扭矩 [Nm]	指减速机输出端所能加载的最大力矩，这个力矩可在减速机寿命期内加载1000次，绝对不能超过1000次。（备注：FPG160/FAB142以下机型为 $T_{2HOT}=2 \cdot T_{2B}$ FAB180以上机型为 $T_{2HOT}=1.5 \cdot T_{2B}$ ）
空载扭矩 T_{012} [Nm]	指加载到减速机上的以克服减速机内摩擦力的力矩。
最大输出扭矩 T_{2B}	指减速机在静态条件或频繁启动条件下所能承受的输出扭矩，通常指峰值负载或启动负载。
实际所需扭矩 T_2 [Nm]	所需扭矩取决于应用场合的实际工况，拟选减速机的额定扭矩 T_{2N} 必须大于这个扭矩。
计算用扭矩 T_{c2} [Nm]	会在选择减速机时被用到，可以由实际所需转矩 T_2 和系数 f_s ，按以下公式得出 $T_{c2}=T_2 \cdot f_s \leq T_N$
侧倾扭矩 [Nm]	指轴向力和径向力作用于输出端轴承上径向受力点的力矩。其计算公式为： $M_{2kmax}=[Fa \cdot Y_2 + Fr \cdot (X_2 + Z_2)]/1000$
轴向力 Fa [N]	是指平行于轴心的一个力，它的作用点与输出轴端有一定的轴向偏差（ Y_2 ）时，会形成一个额外的弯绕力矩。轴向力超过样本所示的额定值时，须用联轴节来抵消这种弯绕力。
径向力 Fr [N]	指垂直作用于轴向力的一个力，它平行于输出轴，它的作用点与轴端有一定的轴向距离（ X_2 ）。这个点成一个杠杆点，横向力形成一个弯绕力矩。
轴伸径向载荷、 轴向载荷	选择减速机的附加依据是输出轴伸出端上的径向载荷和轴向载荷。轴的强度和轴承的承载能力决定了许用轴伸的径向载荷。产品样本中给出的最大允许值是指在最不利的方向作用在轴伸出端中点（即 $1/2L$ 处）的力。当作用力不在中点时，越接近轴肩，允许的径向载荷就越大；相反，作用点离轴肩越远，允许的径向载荷就越小。
安全系数 s	安全系数等于减速机的额定输入功率与电机功率的比值。
使用系数 f_1	使用系数表现减速机的应用特征，它考虑到减速机的负载类型和每日工作时间。
扭转刚度 C_{t21} [Nm/Arcmin]	由加载力矩和所产生的扭转角之间的比率来定义。 $C_{t21}=\Delta T/\Delta \theta$ 它说明需要用多大的力矩才能把输出轴转动一弧分。扭转刚度是从迟滞曲线得出的。在曲线图上只需要关注 T_{2B} 的50%到100%这个范围，在这个范围内，曲线可看成是一条直线。
安装力矩 [Nm]	减速机的组装以及电机与减速机连接安装（输入轴采用弹性联轴节要求），都是有力矩要求。建议使用力矩扳手来完成安装步骤。

Special Notice 特别注意

You can only refer to the input terminal dimension given in this book, special dimension is depend on the shaft extension terminal of chosen motor, practical object's dimension will be difference with these in book, the practical is depend on the finished product, the output terminal dimension is according to these given in this book if not sign.

The weight of reduce motor given in this book is approximation, the practical is depend on the finished product. 本书给出的所有减速机输入端尺寸仅供参考，具体尺寸由适配电机的轴伸端尺寸决定，因此实物外形尺寸与本手册有所差异，应以订购货品的标准图纸为准，在没有特殊制定状态下减速机的输出端尺寸以本书为准。本书给出的所有减速机重量为近似值，实际重量以实物为准。书中错误之处还请见谅。

YPGX Series



機種・形式記號(Model Type mark)

YPGX-090

减速机型式:

YPGX-042
YPGX-060
YPGX-090
YPGX-115
YPGX-142
YPGX-180
YPGX-220

10

减速比:

单级 (L1)
3, 4, 5, 6
7, 8, 10

双级 (L2)
12, 15, 20, 25
30, 35, 40, 50
60, 70, 80, 100

S2

输出轴型式:

S1: 平滑直轴
S2: 附键直轴

P2

背隙:

单级 (L1)
P2: 5分

双级 (L2)

P2: 7分

马达

马达型号:

制造商及型号

减速机性能资料 / GEAR BOX PERFORMANCE INFORMATION

规格		级数	减速比 ¹	YPGX042	YPGX060	YPGX090	YPGX115	YPGX142	YPGX180	YPGX220
额定输出力矩T _{2N}	Nm	1	3	20	55	130	208	342	588	1,140
			4	19	50	140	290	542	1,050	1,700
			5	22	60	160	330	650	1,200	2,000
			6	20	55	150	310	600	-	-
			7	19	50	140	300	550	1,100	1,800
			8	17	45	120	260	500	1,000	1,600
		10	14	40	100	230	450	520	1,220	
		2	12	20	55	130	208	342	-	-
			15	20	55	130	208	342	588	1,140
			20	19	50	140	290	542	1,050	1,700
			25	22	60	160	330	650	1,200	2,000
			30	22	50	130	208	342	1,200	2,000
			35	22	60	160	330	650	1,200	2,000
			40	22	50	140	290	542	1,200	2,000
			50	22	60	160	330	650	1,200	2,000
			60	20	55	150	310	600	-	-
			70	19	50	140	300	550	1,100	1,800
			80	17	45	120	260	500	1,000	1,600
100	14		40	100	230	450	520	1,220		
最大输出力矩T _{2B}	Nm	1,2	3~100	3倍额定输出力矩						
额定输入转速n ₁	rpm	1,2	3~100	5,000	5,000	4,000	4,000	3,000	3,000	2,000
最大输入转速n _{1B}	rpm	1,2	3~100	10,000	10,000	8,000	8,000	6,000	6,000	4,000
背隙	arcmin	1	3~10	≤5	≤5	≤5	≤5	≤5	≤5	≤5
		2	12~100	≤7	≤7	≤7	≤7	≤7	≤7	≤7
扭转刚性	Nm/arcmin	1,2	3~100	3	7	14	25	50	145	225
容许径向力F _{2rB} ²	N	1,2	3~100	780	1,530	3,250	6,700	9,400	14,500	50,000
容许轴向力F _{2a1B} ²	N	1,2	3~100	350	630	1,300	3,000	4,000	6,200	35,000
容许轴向力F _{2a2B} ²	N	1,2	3~100	390	765	1,625	3,350	4,700	7,250	25,000
使用寿命	hr	1,2	3~100	20,000*						
效率 η	%	1	3~10	≥97%						
		2	12~100	≥94%						
重量	kg	1	3~10	0.5	1.3	3.7	7.8	14.5	29	48
		2	12~100	0.8	1.9	4.1	9	17.5	33	60
使用温度	°C	1,2	3~100	-10°C~+90°C						
润滑		1,2	3~100	合成润滑油脂						
防护等级		1,2	3~100	IP65						
安装方向		1,2	3~100	任意方向						
噪音值 (n ₁ =3000rpm)	dB	1,2	3~100	≤56	≤58	≤60	≤63	≤65	≤67	≤70

减速机转动惯量

规格		级数	减速比 ¹	YPGX042	YPGX060	YPGX090	YPGX115	YPGX142	YPGX180	YPGX220
转动惯量J _i	kg·cm ²	1	3	0.03	0.16	0.61	3.25	9.21	28.98	69.61
			4	0.03	0.14	0.48	2.74	7.54	23.67	54.37
			5	0.03	0.13	0.47	2.71	7.42	23.29	53.27
			6	0.03	0.13	0.45	2.65	7.25	22.75	51.72
			7	0.03	0.13	0.45	2.62	7.14	22.48	50.97
			8	0.03	0.13	0.44	2.58	7.07	22.59	50.84
		10	0.03	0.13	0.44	2.57	7.03	22.51	50.56	
		2	12	0.03	0.03	0.13	0.47	2.71	7.42	23.29
			15	0.03	0.03	0.13	0.47	2.71	7.42	23.29
			20	0.03	0.03	0.13	0.47	2.71	7.42	23.29
			25	0.03	0.03	0.13	0.47	2.71	7.42	23.29
			30	0.03	0.03	0.13	0.47	2.71	7.42	23.29
			35	0.03	0.03	0.13	0.47	2.71	7.42	23.29
			40	0.03	0.03	0.13	0.47	2.71	7.42	23.29
			50	0.03	0.03	0.13	0.44	2.57	7.03	22.51
			60	0.03	0.03	0.13	0.44	2.57	7.03	22.51
			70	0.03	0.03	0.13	0.44	2.57	7.03	22.51
			80	0.03	0.03	0.13	0.44	2.57	7.03	22.51
100	0.03		0.03	0.13	0.44	2.57	7.03	22.51		

1. 减速比 (i=N_{in}/N_{out})

* 连续运转降低使用寿命二分之一。

2. 输出转速 100rpm 时，作用于输出轴中心位置。

YPGX-042-L1

输入轴内径 Input shaft bore $\leq \phi 8$

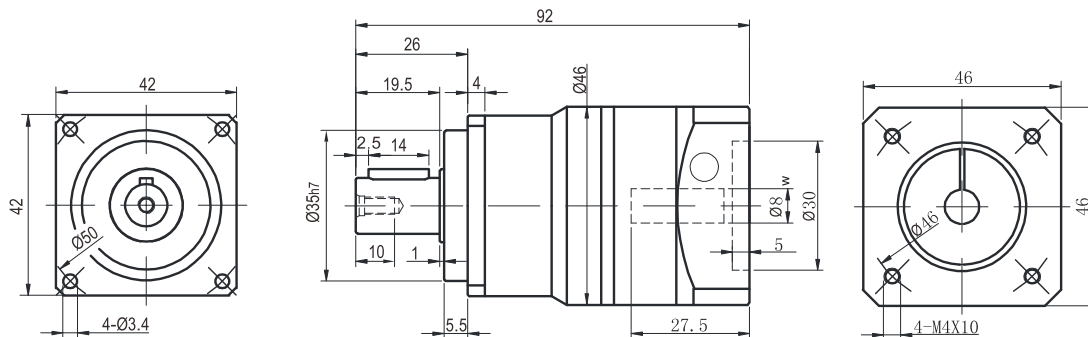

YPGX-042-L1

输入轴内径 Input shaft bore $\leq \phi 11$

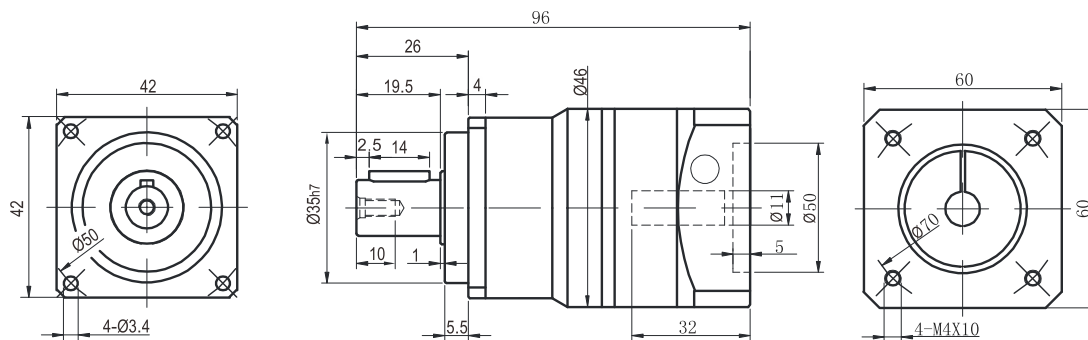

YPGX-042-L2

输入轴内径 Input shaft bore $\leq \phi 8$

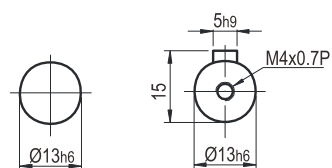
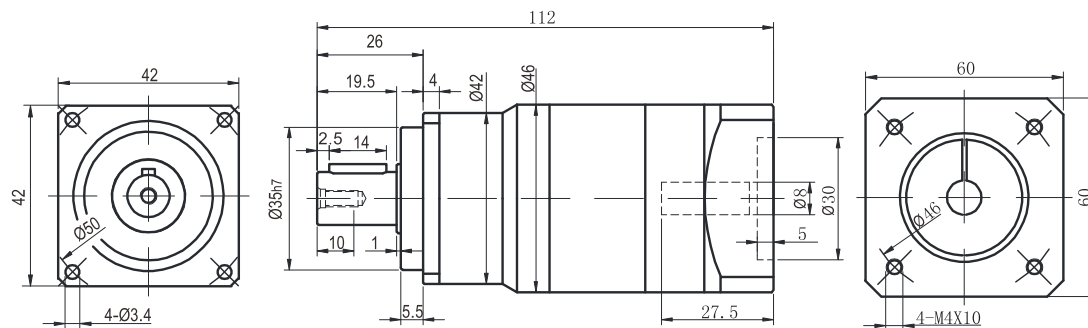

轴型式 S1

轴型式 S2

- ※1 视安装马达的不同而有所差异。
- ※2 马达轴径与输入轴径不同时, 可插入轴套。
- ※1 Length will vary depending on motor.
- ※2 Bushing will be inserted to adapt to motor shaft.

YPGX-060-L1

输入轴内径 Input shaft bore $\leq \phi 14$

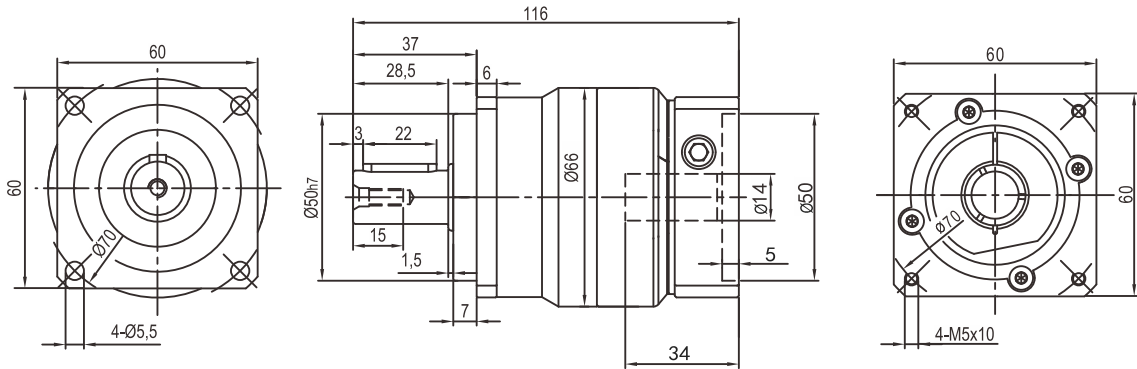

YPGX-060-L1

输入轴内径 Input shaft bore $\leq \phi 19$

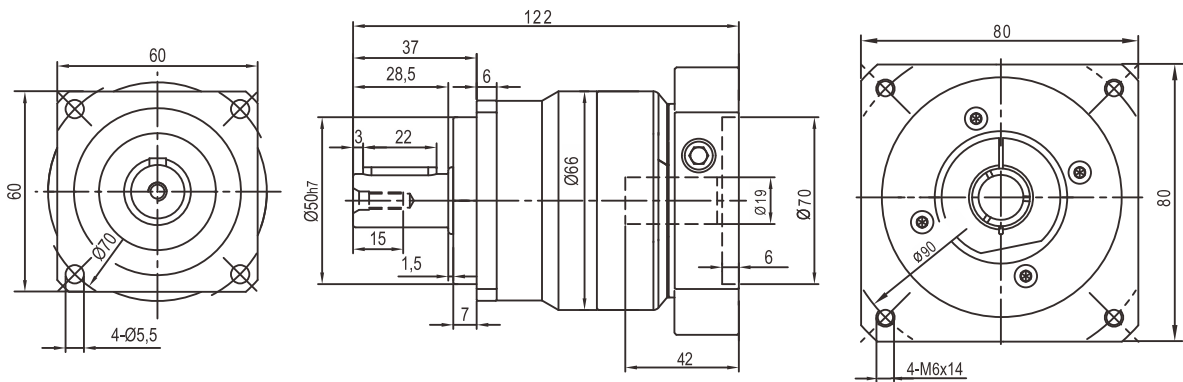

YPGX-060-L2

输入轴内径 Input shaft bore $\leq \phi 14$

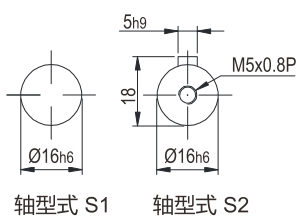
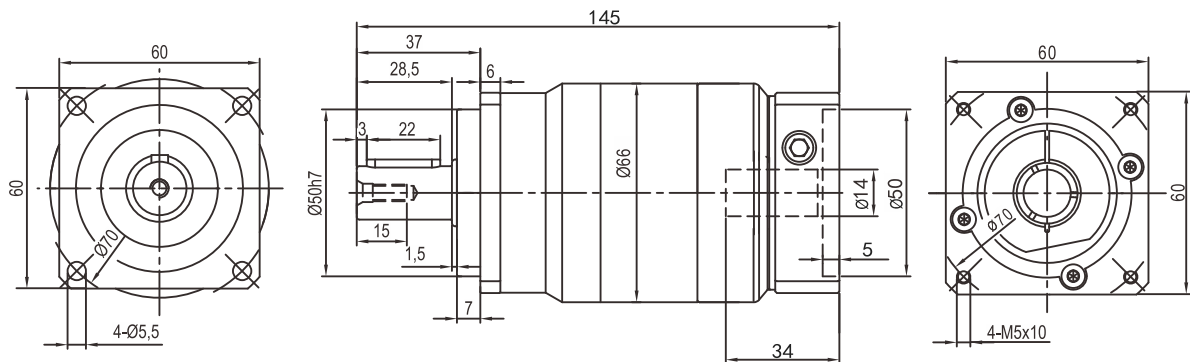

- ※1 视安装马达的不同而有所差异。
- ※2 马达轴径与输入轴径不同时，可插入轴套。
- ※1 Length will vary depending on motor.
- ※2 Bushing will be inserted to adapt to motor shaft.

YPGX-090-L1

输入轴内径 Input shaft bore $\leq \phi 16$

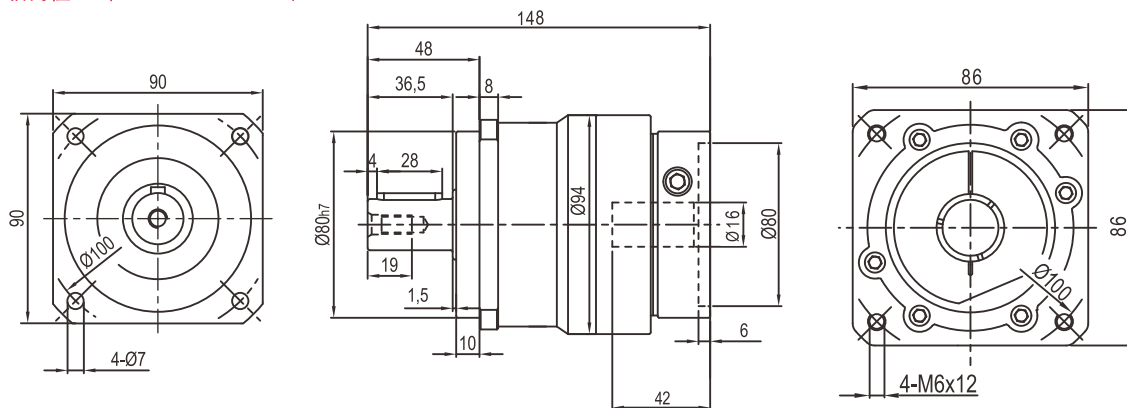

YPGX-090-L1

输入轴内径 Input shaft bore $\leq \phi 19$

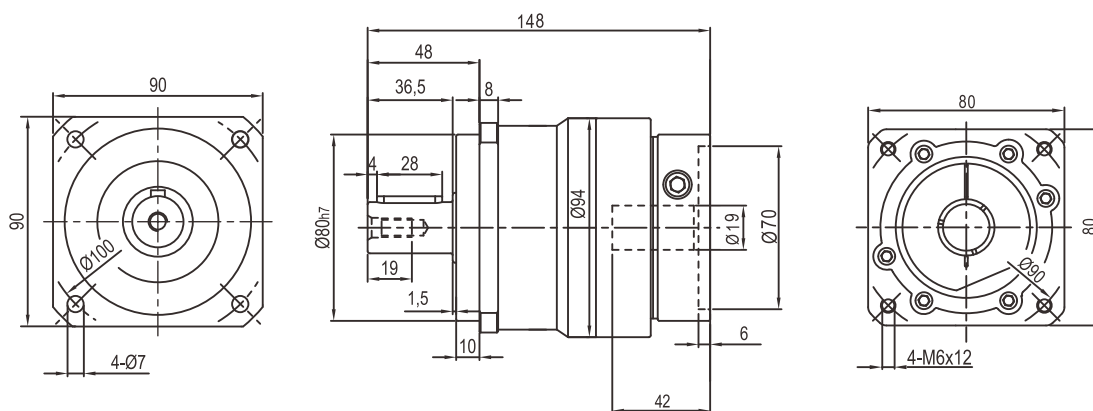

YPGX-090-L1

输入轴内径 Input shaft bore $\leq \phi 24$

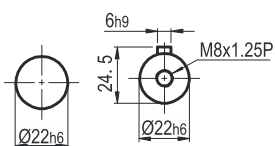
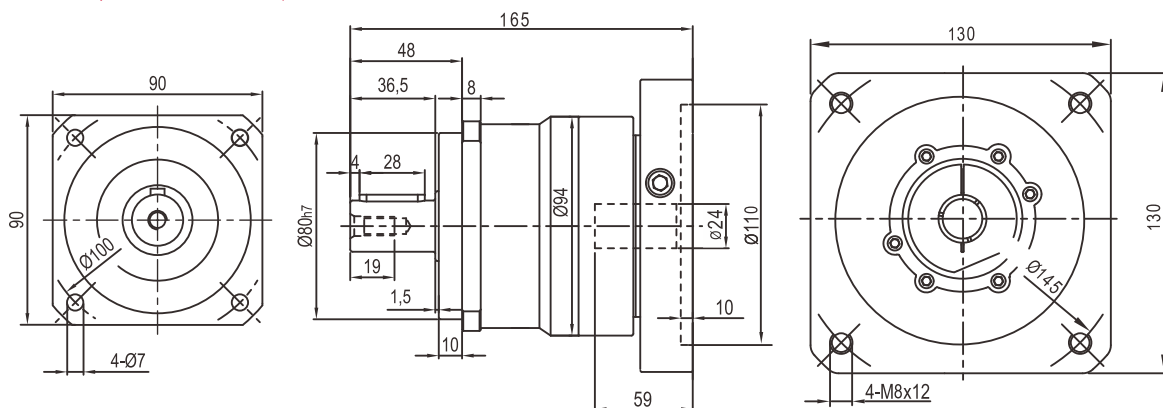

轴型式 S1 轴型式 S2

- ※1 视安装马达的不同而有所差异。
- ※2 马达轴径与输入轴径不同时, 可插入轴套。
- ※1 Length will vary depending on motor.
- ※2 Bushing will be inserted to adapt to motor shaft.

YPGX-090-L2

输入轴内径 Input shaft bore $\leq \phi 14$

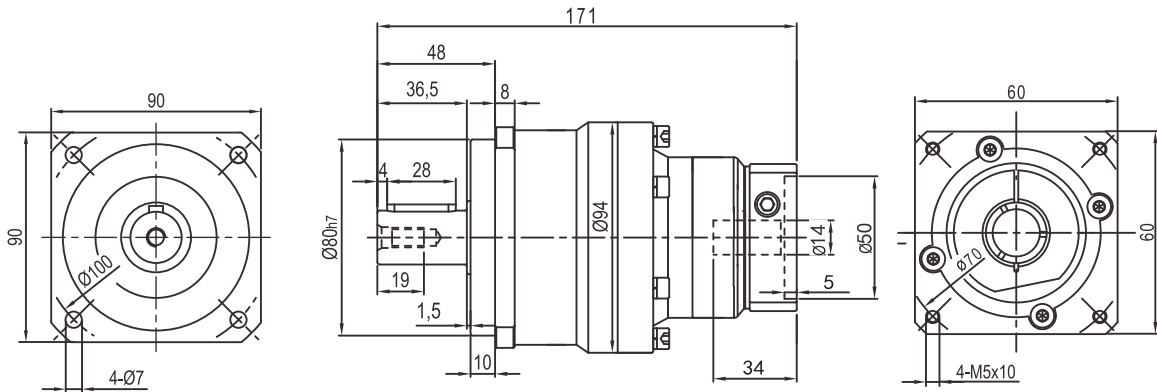

YPGX-090-L2

输入轴内径 Input shaft bore $\leq \phi 16$

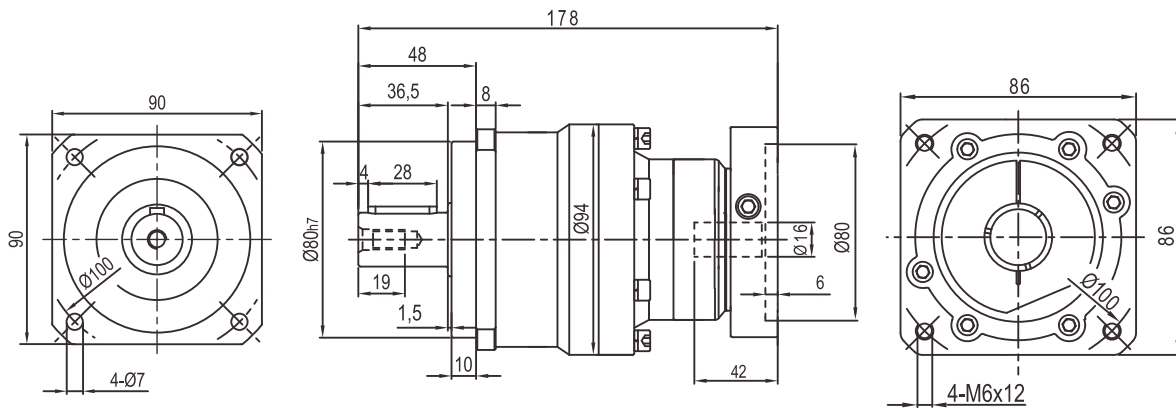

YPGX-090-L2

输入轴内径 Input shaft bore $\leq \phi 19$

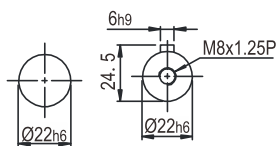
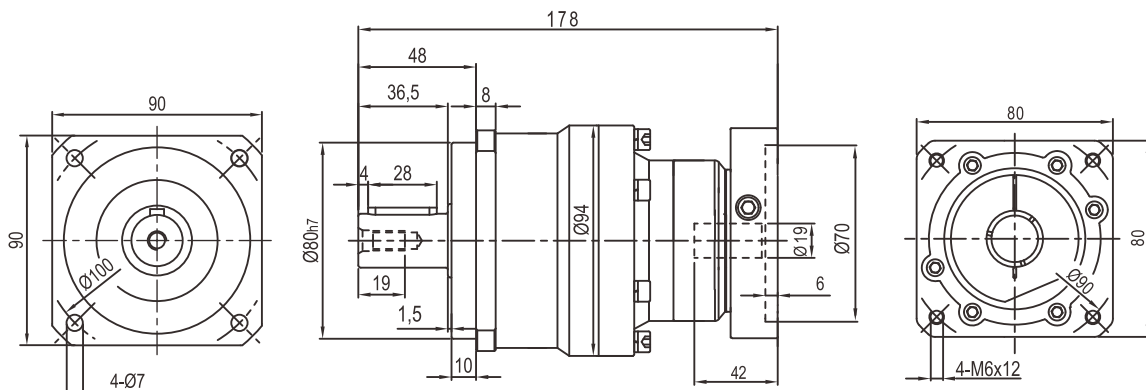

轴型式 S1 轴型式 S2

- ※1 视安装马达的不同而有所差异。
- ※2 马达轴径与输入轴径不同时, 可插入轴套。
- ※1 Length will vary depending on motor.
- ※2 Bushing will be inserted to adapt to motor shaft.

YPGX-115-L1

输入轴内径 Input shaft bore $\leq \phi 24$

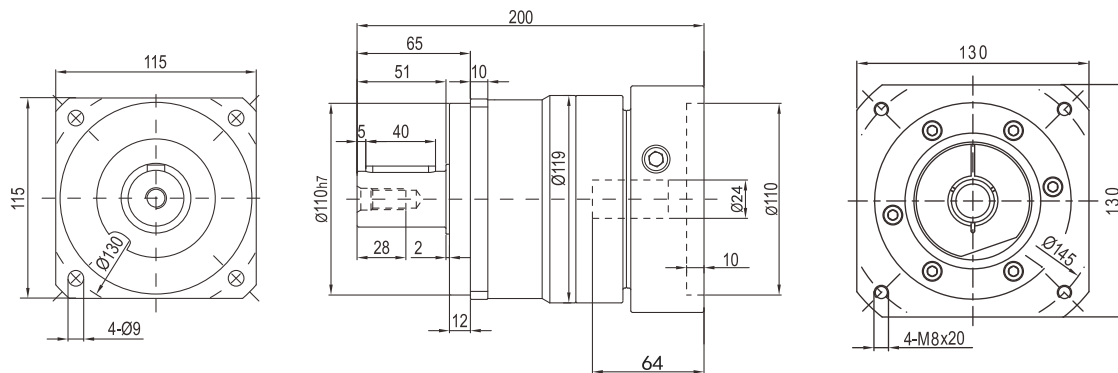

YPGX-115-L2

输入轴内径 Input shaft bore $\leq \phi 19$

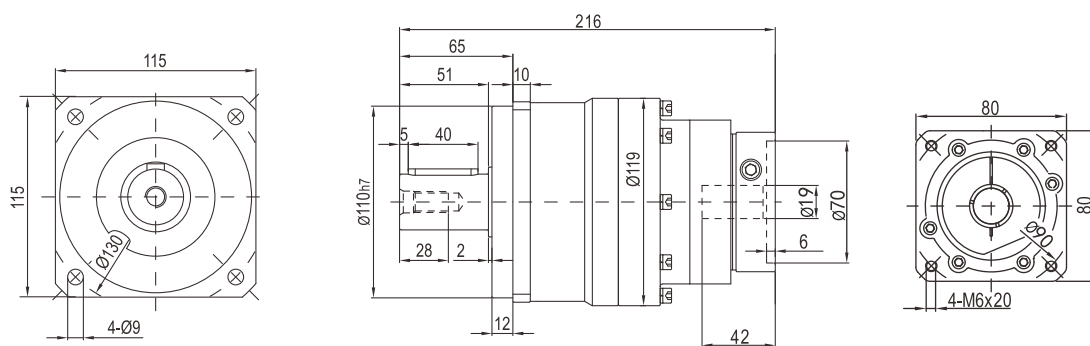

YPGX-115-L2

输入轴内径 Input shaft bore $\leq \phi 24$

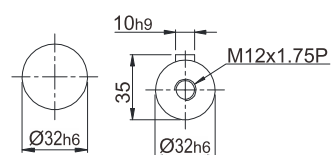
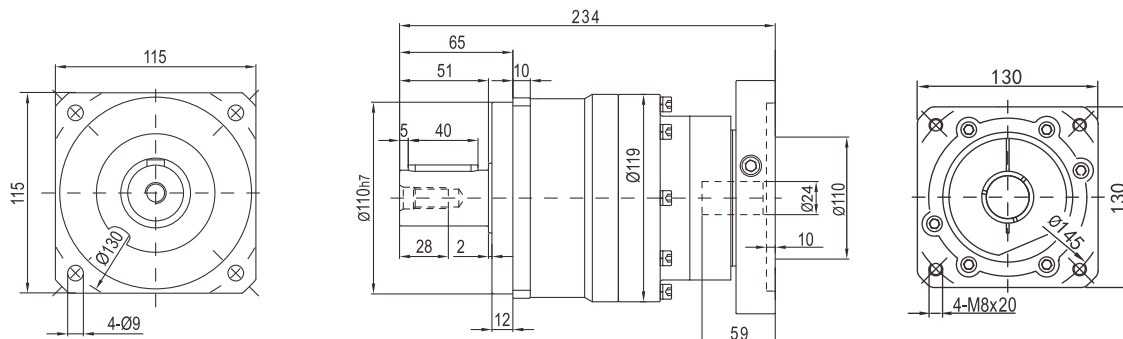

轴型式 S1 轴型式 S2

- ※1 视安装马达的不同而有所差异。
- ※2 马达轴径与输入轴径不同时, 可插入轴套。
- ※1 Length will vary depending on motor.
- ※2 Bushing will be inserted to adapt to motor shaft.

YPGX-142-L1

输入轴内径 Input shaft bore $\leq \phi 35$

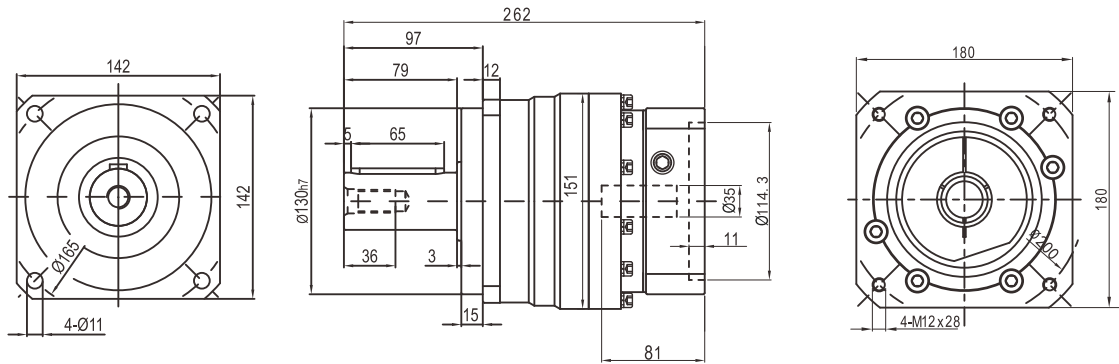

YPGX-142-L2

输入轴内径 Input shaft bore $\leq \phi 24$

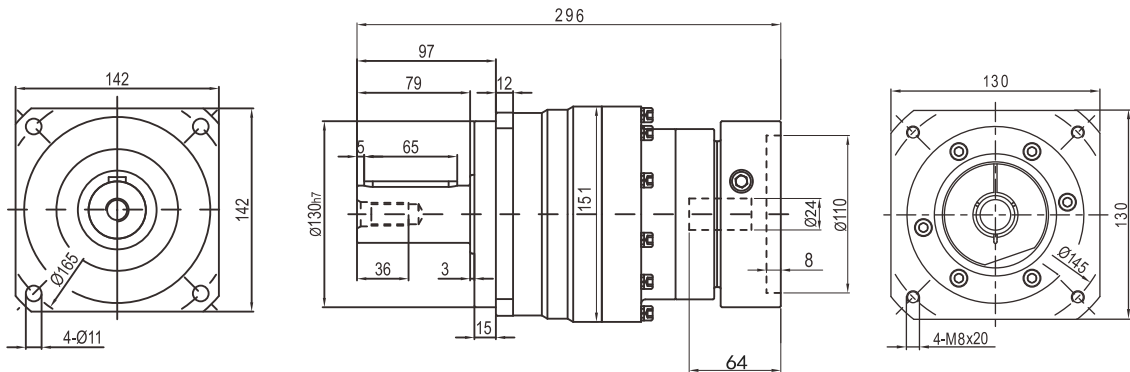

YPGX-142-L2

输入轴内径 Input shaft bore $\leq \phi 35$

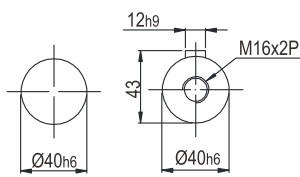
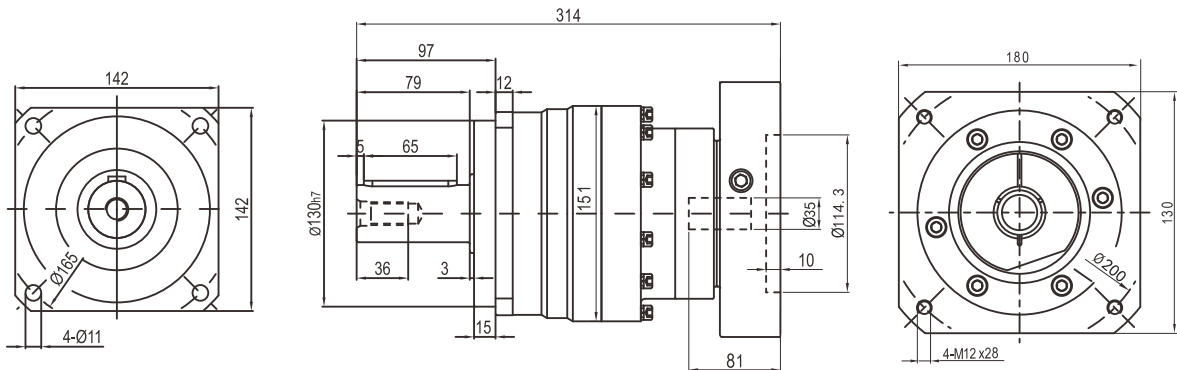

轴型式 S1 轴型式 S2

- ※ 1 视安装马达的不同而有所差异。
- ※ 2 马达轴径与输入轴径不同时, 可插入轴套。
- ※ 1 Length will vary depending on motor.
- ※ 2 Bushing will be inserted to adapt to motor shaft.

YPGX-180-L1

输入轴内径 Input shaft bore $\leq \phi 35$

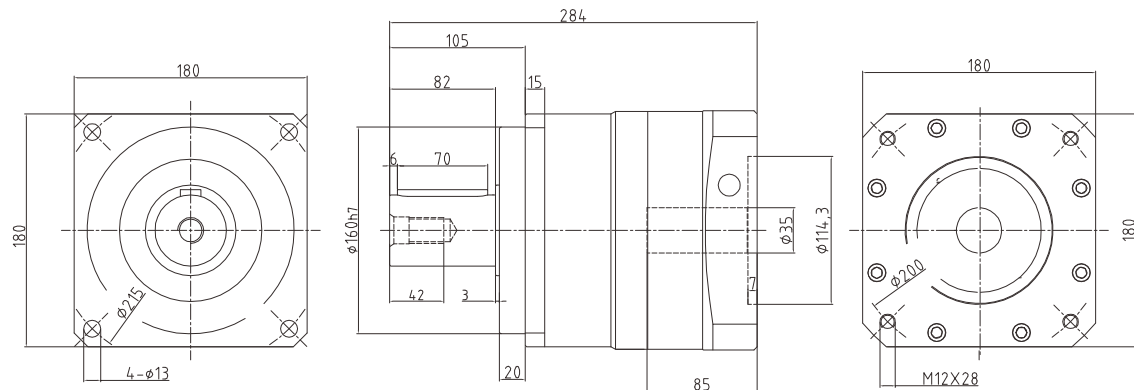

YPGX-180-L1

输入轴内径 Input shaft bore $\leq \phi 42$

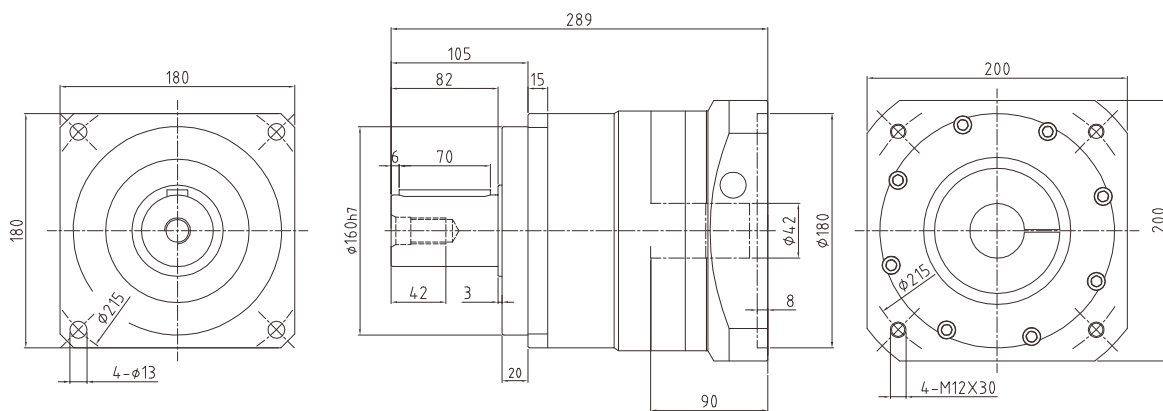

YPGX-180-L2

输入轴内径 Input shaft bore $\leq \phi 35$

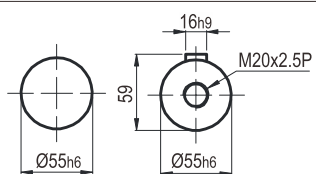
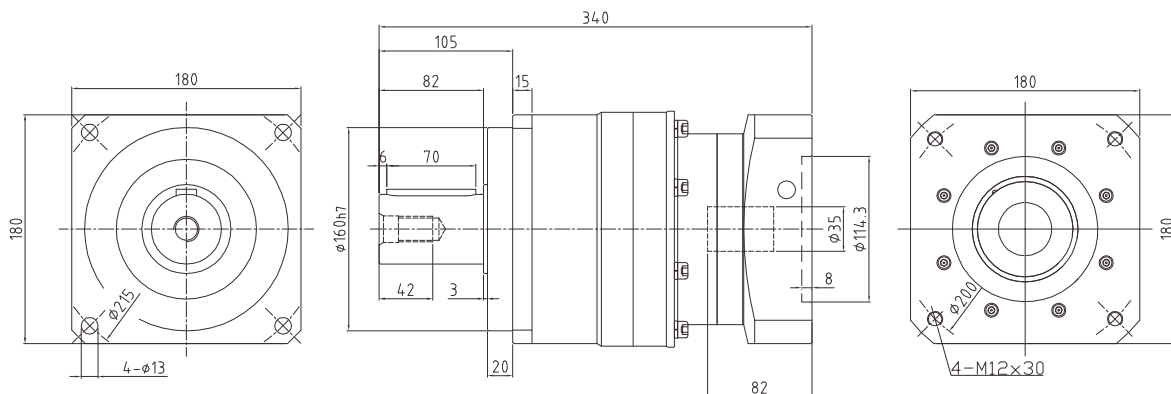

轴型式 S1 轴型式 S2

- ※1 视安装马达的不同而有所差异。
- ※2 马达轴径与输入轴径不同时, 可插入轴套。
- ※1 Length will vary depending on motor.
- ※2 Bushing will be inserted to adapt to motor shaft.

YPGX-220-L1

输入轴内径 Input shaft bore $\leq \phi 55$

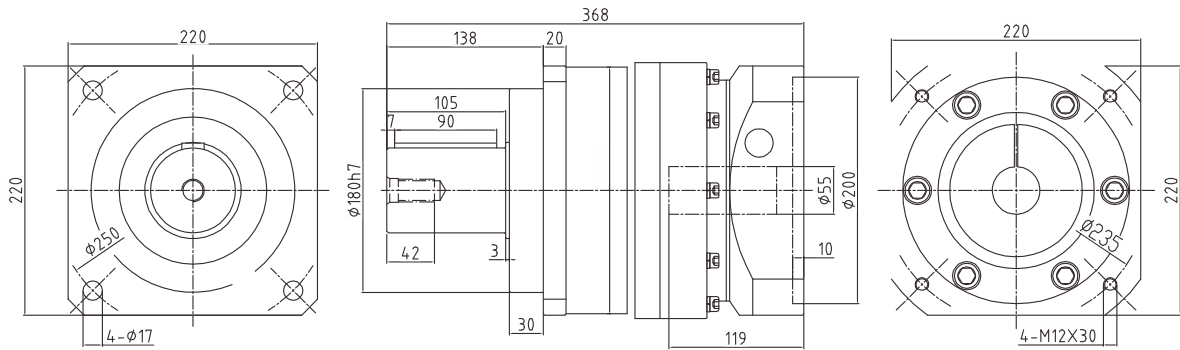

YPGX-220-L2

输入轴内径 Input shaft bore $\leq \phi 35$

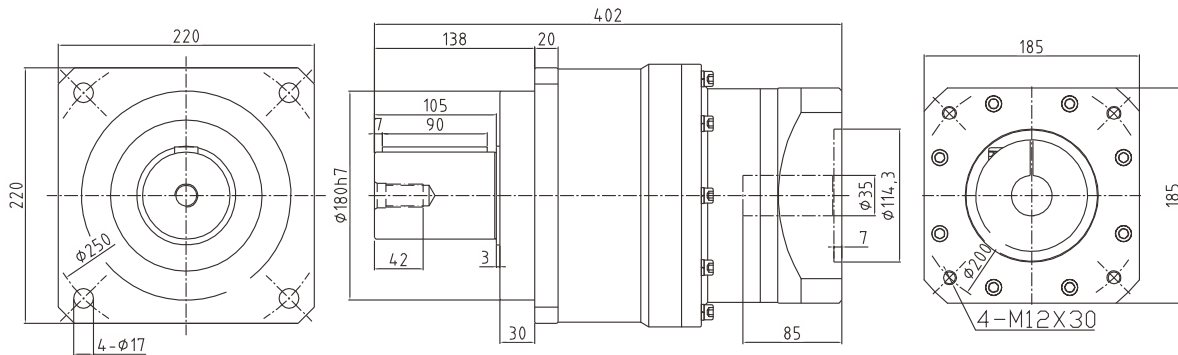

YPGX-220-L2

输入轴内径 Input shaft bore $\leq \phi 42$

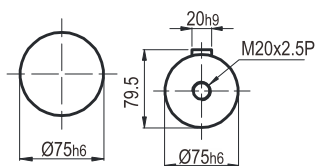
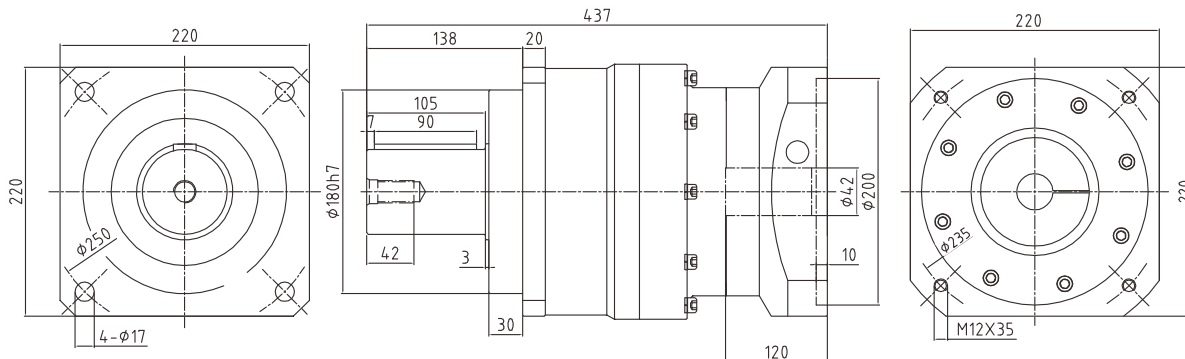

轴型式 S1 轴型式 S2

- ※ 1 视安装马达的不同而有所差异。
- ※ 2 马达轴径与输入轴径不同时, 可插入轴套。
- ※ 1 Length will vary depending on motor.
- ※ 2 Bushing will be inserted to adapt to motor shaft.

马达安装说明 / MOTOR INSTALLATION INSTRUCTIONS



① 确认马达与减速机规格，并将马达及减速机之安装面擦拭干净。



② 将入力法兰侧孔堵头螺丝取出，转动马达锁紧鞍，直到锁紧鞍螺丝对准法兰侧孔。

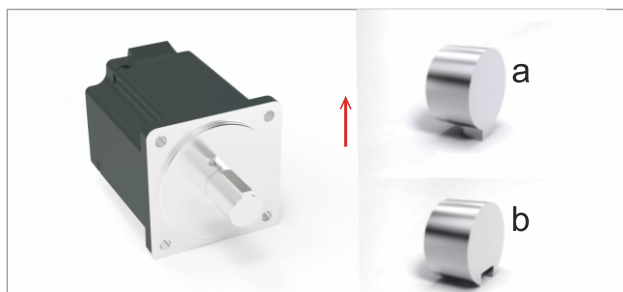

③ 取下马达上原先之平键；如有必要，请安装平衡键。

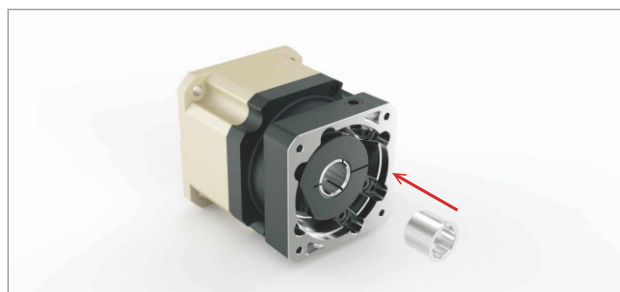

④ 确认马达轴心尺寸，若有必要，装上轴套。

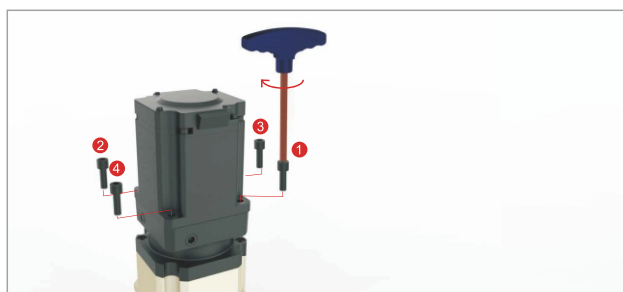

⑤ 直立式的装入马达，以螺丝扭力表（表一）建议扭力值之5%，依1~4的顺序，用扳手将附垫片之螺丝轻轻锁上。

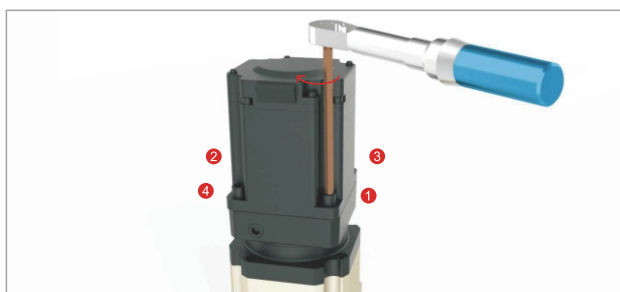

⑥ 将马达与减速机直立摆设，以螺丝扭力表（表一）建议扭力值，依1~4的顺序，用扭力扳手将螺丝锁紧。



⑦ 参照表二建议之扭力值，用扭力扳手将马达锁紧鞍螺丝锁紧。

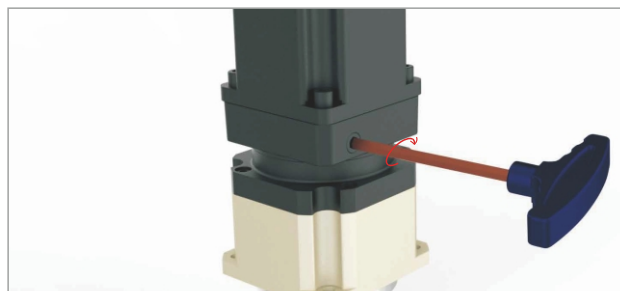

⑧ 锁回法兰侧孔堵头螺丝。

马达安装说明 / MOTOR INSTALLATION INSTRUCTIONS

表一 马达锁紧螺丝扭力建议表

螺丝尺寸	六角头尺寸	强度8.8螺丝之锁紧扭力		强度10.9螺丝之锁紧扭力		强度12.9螺丝之锁紧扭力	
	[mm]	[Nm]	[In-lbs]	[Nm]	[In-lbs]	[Nm]	[In-lbs]
M3 x 0.5P	2.5	1.3	12	1.8	16	2.1	19
M4 x 0.7P	3	3	27	4.1	37	4.9	44
M5 x 0.8P	4	6.1	55	8.2	73	9.8	87
M6 x 1P	5	11	98	14	124	17	151
M8 x 1.25P	6	25	222	34	302	41	364
M10 x 1.5P	8	49	434	67	594	80	709
M12 x 1.75P	10	85	753	116	1028	139	1232
M14 x 2P	12	137	1214	186	1648	223	1976
M16 x 2P	14	210	1860	286	2534	343	3038

表二 马达锁紧螺丝扭力建议表

减速机型号	马达轴径	螺丝尺寸	六角头尺寸	锁紧扭力	
	[mm]	[mm]	[mm]	[Nm]	[In-lbs]
单级	≤12	M3 x 0.5P x 8L	2.5	2.1	19
双级	≤12	M3 x 0.5P x 8L	2.5	2.1	19
单级	≤19	M4 x 0.7P x 12L	3	4.9	44
双级	≤19	M4 x 0.7P x 12L	3	4.9	44
单级	≤24	M5 x 0.8P x 20L	4	9.8	87
双级	≤19	M4 x 0.7P x 12L	3	4.9	44
单级	≤35	M8 x 1.25P x 30L	6	41	364
双级	≤24	M5 x 0.8P x 20L	4	9.8	87
单级	≤38	M10 x 1.5P x 30L	8	80	709
双级	≤35	M8 x 1.25P x 30L	6	41	364
单级	≤50	M12 x 1.75P x 35L	10	139	1232
双级	≤38	M10 x 1.5P x 30L	8	80	709
单级	≤55	M16 x 2P x 40L	14	343	3038
双级	≤50	M12 x 1.75P x 35L	10	139	1232

备注：螺丝锁紧扭力必须大于上述值。若有需要时，可将锁紧扭力多增加上述建议值之20%，以避免打滑。

保管時的注意事項

需要暫時保管本產品時，
請遵照下列要領進行。

- ① 放在清潔乾燥的場所進行保管。
- ② 若放在室外或有潮氣的場所保管時，應裝入箱內并用塑料等嚴密包裹，以避免受雨淋或外氣的侵蝕(採取防結露、生銹措施)。

Cautions for storage

Whenever temporarily keeping the product,
keep the following directions:

- ① Keep in a clean and dry place.
- ② Whenever storing outdoors or in a humid place, put in a box so that it does not directly contact rain or external air and cover with a vinyl sheet(Take a measure to prevent rust).

■ 運行時的注意事項

■ 減速機到廠後...

- 減速機到貨後請確認減速機型號是否與訂購的型號相同。
- 減速機輸出軸、輸入軸上塗有防銹劑，請擦拭後使用。
- ※取下輸入軸的橡膠栓，擦拭防銹劑。
- ※減速機上已充填完潤滑油(油脂)。
- 本機到廠後即可使用。

■ 安裝、設置

- 請勿在會直接淋到雨或水的場所使用。
 - 需要在室外或受粉塵、水滴影響的場所使用時，請事先與本公司聯繫。
- 請將本機設置在周圍溫度為0℃~40℃的環境中。
 - 如在上述範圍外的溫度中使用本機時，必須與本公司聯繫。
- 將本機設置在不曾振動且堅固的安裝臺上，并用螺栓緊固。
- 設置時應考慮到保養維修的便利性。

■ 運行開始前的注意事項

- 本公司產品出貨時已填充了規定量的潤滑脂，到貨後可直接使用。
- 初次運行時，應先確認輸出軸的旋轉方向後，再慢慢地增加負荷。

■ 運行中的注意事項

- 應注意不要超負荷。
- 輸入轉速不得超過規定以上的轉速。
- 發生下列情況時，請暫停運行立即進行檢查。
 - 溫度突然上升
 - 突然出現很大的異常聲
 - 轉速突然變得不穩定

● 保修規定

- 產品的保修對象地區限于大陸區域內。
- 保修範圍祇限交付產品單體。
- 以下費用和損害不在保修範圍內。
 - 1) 本產品的運輸費。
 - 2) 本產品與其它裝置等連接或裝入後從該裝置等上拆下、安裝或其它附帶施工的費用。
 - 3) 因本產品的故障，發生了使利用者失去使用機會或業務中斷等造成的間接損害。
 - 4) 其它所有派生的或伴隨的損害。

■ Cautions for operation

■ When the reducer is delivered to you . . .

- When the product delivered, please confirm that you received the exact same model you have ordered.
Please wipe out the input and output shaft of the reducer which is covered by anti-corrosive oil.
※Please remove the rubber cap on the input shaft before you wipe the shafts.
※Lubricant(grease) is already filled in the reducer.
It is available as it is.

■ Fixation & installation

- Avoid use in a place where rain or water drops directly.
 - In case of use outdoors or in a place where dust and water drops, consult in advance.
- Install at 0℃~40℃ of surrounding temperature.
 - In case of use at temperature out of the above-mentioned range, contact the headquarters and consult on this.
- Firmly fix with a bolt onto a solid stand without vibration.
- Install in consideration of convenience in repair and inspection.

■ Cautions prior to starting the operation

- Reducer can be used soon after arrival, since it has already been filled out with lubrication.
- At initial operation, check the rotating direction of the output shaft and then gradually apply load.

■ Cautions during operation

- Avoid overload.
- Ensure that input speed shall not be the number of revolutions beyond the specification.
- In the following cases, stop the operation and check the following points:
 - If temperature sharply increases
 - If an abnormal noise appears sharply
 - If the number of revolutions becomes unstable sharply

安全注意事項

SAFETY PRECAUTIONS

- 如果這些原因是由下列事項造成，應馬上採取應對措施或與本公司聯繫。
 - 是否處於超負荷狀態？
 - 是否潤滑油不足、老化或使用不同品種的潤滑油？
 - 軸承、齒輪、傳動面有無損傷？
 - 是否與關聯機械連接等的條件不良？

■ 分解

- 減速機為不能分解的結構。

■ 保修

- 保修期間為交付產品後起1年。

■ 潤滑油管理

- 減速機的全部機種均採用潤滑脂潤滑密封方式。出廠前已充填了定量的潤滑油，到廠後即可使用。
- 不能更換潤滑脂。
- 在周圍溫度常時0℃~40℃以外的環境中使用時，請事先諮詢本公司。

■ 每天檢查

- 運行中的減速機的外殼溫度有無異常增高。
(如果周圍溫度在+50℃以內的話，沒有大問題)
- 軸承、齒輪部等有無異常聲音。
- 減速機有無異常振動。
 - * 如果發生這些現象時，請立即停機並與本公司聯繫。
- 潤滑油有無泄漏。
 - * 發生油脂泄漏時，請與本公司聯繫。

■ 定期檢查

- 有無超負荷或異常旋轉。
- 滑輪、鏈輪、減速機安裝螺栓等有無鬆動。
- 電氣系統有無異常。
- 主要部件的檢查和維護
 - * 發生異常現象時，請立即停機並與本公司聯繫。
- 潤滑油的問題
 - * 發生油脂泄漏時，請與本公司聯繫。

■ 廢棄方法

廢棄減速機時，應根據法令和各自自治體的條例等，將部件按材料分類，作為產業廢棄物進行處理。

部件材料分成以下4種。

- ① 橡膠制部件：油封、密封墊圈、橡膠蓋、馬達法蘭側的軸承上使用的密封部
- ② 鋁制部件：馬達法蘭、輸出軸座
- ③ 潤滑脂：用幹布等擦拭附在部件上的潤滑脂，作為油類廢棄
- ④ 鐵制部件：上述以外的部件

- These may be caused by the following matters, so rapidly respond to it or contact us.
 - Is it under overload condition?
 - Is lubricant insufficient or deteriorated, or is lubricant of other type used?
 - Is the axis, gear, and motor side damaged?
 - Is jointing with other machines poor?

■ Disassembly

- REDUCER is designed not to allow disassembly.

■ Warranty

- A warranty period is one year after the product is delivered to you.

■ Lubricant use

- The REDUCER is of grease-seal type in all models. A specified amount of grease is filled at factory release, so you can use as soon as it is delivered to you.
- It is impossible to exchange grease.
- In case of use at 0℃~40℃ of surrounding temperature at usual times, consider this in advance.

■ Daily check points

- Is reducer case temperature excessively high during operation? (Up to +50℃ is not significant.)
- Is there an abnormal noise in the bearing, gear, etc?
- Is there abnormal vibration in the reducer?
 - * Upon an abnormal phenomenon, immediately stop the operation and contact us.
- Is there a lubricant leak?
 - * Upon an oil leak, contact us.

■ Periodic check points

- Are there overload and abnormal rotation?
- Are free, sprocket, and reducer assembling bolts loose?
- Is there an abnormal condition in the electric system?
- Checkup and repair of major parts
 - * Upon an abnormal condition, immediately stop the operation and contact us.
- Oil leak
 - * Upon an oil leak, contact us.

■ Scrapping

Whenever scrapping the REDUCER, classify the parts by material into industrial wastes as specified in the laws and regulations of self-governing bodies. Material of parts can be divided into four:

- ① Rubber parts : Oil seal, seat packing, rubber cap, seal used for bearing on the motor flange, etc.
- ② Aluminum parts : Motor flange, output shaft holder
- ③ Grease : Wipe off grease attached to parts with dry cloth and scrap into oils.
- ④ Iron parts : Parts other than those mentioned in the above

WARRANTY PROVISION

- Product warranty subject is only mainland area.
- Warranty scope is the delivered product only.

■ THE EXPENSES AND LOSSES THAT MENTIONED BELOW ARE NOT INCLUDED IN WARRANTY

- 1)The transport charges for repairing of our products.
- 2)The fee for the removal operation, reinstallation and other related operation in case our product is installed to the other machine.
- 3)The loss of the chances of use and indirect damages caused by the interruption of the services caused by our product's defects.
- 4)All other secondary expenses and losses.

伺服馬達廠家一覽表 Servo Motor Manufacturer List

■日本國主要伺服馬達廠家 Japanese Servo Motor Manufacturer

Panasonic 株式會社 Panasonic Corporation	東芝機械株式會社 TOSHIBA MACHINE CO.,LTD.
株式會社安川電機 YASKAWA Electric Corporation	FANUC 株式會社 FANUC CORPORATION
三菱电机株式会社 Mitsubishi Electric Corporation	多摩川精機株式會社 TAMAGAWA SEIKI CO.,LTD.
富士電機株式會社 FUJI ELECTRIC CO.,LTD.	日機電裝株式會社 Nikki Denso
歐姆龍株式會社 OMRON Corporation	株式會社日立產機系統 Hitachi Industrial Equipment Systems Co.,Ltd.
山洋電氣株式會社 SANYO DENKI CO.,LTD.	株式會社三明 Sanmei Co.,Inc.
株式會社基恩士 KEYENCE CORPORATION.	日本電產三協株式會社 NIDEC SANKYO CORPORATION

■國外主要伺服馬達廠家 Global Servo Motor Manufacturer

ALLEN BRADLEY	BECKHOFF
ABB	LENZE
B&R	LUST
BALDOR	PARKER
BAUMULLER	SAMSUNG
BOSCH REXROTH	SCHNEIDER
DELTA	SIEMENS
EMERSON (CONTROL TECHNIQUES)	TECO
ESTUN	GOLDEN AGE

* 本公司也承辦上述以外的伺服馬達廠家、伺服馬達和步進電機等系列業務，請諮詢本公司。

* The company also hosted a servo motor manufacturers, servo motors and stepper motors, and other business other than the above, please contact the company.

 安全注意事項

- ◆ 使用前，請先仔細閱讀使用說明書後再以正確的方式操作使用。
- ◆ 本產品目錄中所刊載的產品為工業用產品及組裝到機器設備中時使用的產品，請勿作其他用途使用



上海动展传动机电有限公司

SHANGHAI DONG ZHAN DRIVE INDUSTRY CO.,LTD.

ADD.: No.126, Lane 255, South Sizhuan Road, Shanghai 201612,China

TEL.:0086 21 59766193; FAX.:0086 21 39294030

E-MAIL.: sales@dzgearmotor.com

WEBSITE: www.dzgearmotor.com